

TFCE9 - 9ltr Foam Extinguisher

Extinguisher Fire Rating - 21A 183B

Cylinder

The mild steel deep drawn cylinder is manufactured from high grade mild steel and is fully compliant with the requirements of BS EN3 and the Pressure Equipment Directive (97/23/EC)

The polyester powder coated exterior has a high gloss, chip resistant finish, and offers excellent corrosion resistance.

The cylinder is internally lined using the latest hot application polythene crystal lining. This has excellent adhesion to the steel cylinder and is completely resistant to AFFF media, ensuring that the lining maintains its integrity and continues to offer excellent internal corrosion resistance.

Use

All ex-celsius extinguishers are operated in the same way. Remember the letters P.A.S.S.

- P** - Pull out the safety pin
- A** - Aim at the base of the fire
- S** - Squeeze the levers to commence discharge, release to stop
- S** - Sweep the flames from side to side

Training in the use of hand portable fire extinguishers is highly recommended, in order for potential users to be familiar with the equipment and its method of operation.

Maintenance

- inspect extinguisher visually, paying particular attention for corrosion, damage and other conditions that may make the extinguisher unsafe for use.
- check pressure gauge is reading within the green sector. Remove the pressure gauge to ensure that it zeros and replace the pressure gauge ensuring that it returns to the original reading.
- remove discharge hose and check for blockages. Replace 'O' ring and refit hose.
- weigh extinguisher and ensure that the weight is in accordance with the manufacturers specification and the weight when first put into service.
- remove safety pin, and ensure that levers are free to move. Refit safety pin and fit new anti-tamper tag.
- record details of service on service label and return to service, ensuring that any hanging bracket is of the correct type and is securely attached to the wall.

Recharge Instructions

Before removing the valve, ensure all pressure has been released by inverting the extinguisher and squeezing the levers. Slowly remove valve, ensuring any residual pressure is released before completely removing the valve.

Empty any residual extinguishant from the cylinder and dispose of, paying attention to any environmental requirements for the type of media.

Carefully examine the interior of the cylinder paying particular attention to any corrosion of the neck threads.

Refill the cylinder with the correct amount of extinguishant, as specified by the manufacturer.

Examine the valve, and ensure that it is operating correctly and replace main 'O' ring with a new one before refitting.

Tighten the valve so that the gauge lines up with the centre of the operating instructions.

Repressurise using Nitrogen to a pressure of 14 Bar.

Record recharge information on the service label and return to service.

AFFF Extinguishers

ex-celsius extinguishers use a high quality 3% AFFF additive, which is highly effective on both Class A and B fires. Due to the spray foam nozzle, the extinguisher has passed the EN3 35000Volt test, meaning the user is safe if the extinguisher is used on live electrical equipment, although AFFF extinguishers should not be recommended for areas where the main risk is a fire involving live electrical equipment. CO₂ or Powder is more suitable.

BS EN3

ex-celsius extinguishers are manufactured and tested in accordance with BS EN3. This standard specifies requirements for performance, safety, corrosion resistance, consistency, use of the extinguishers at both ends of its temperature range, colour and marking, etc. As part of the Kitemark approval samples are regularly tested by BSI to ensure continuing compliance with the requirements, and the manufacturing plant is regularly audited to ensure that approved processes continue to be applied.

Extinguisher Fire Rating - 21A 183B



Woods, Paper, Textiles



Flammable Liquids such as petrol, paraffin, paints, oils



Safe to use on electrical equipment of up to 1000V at a distance of 1m

Colour coding

All ex-celsius extinguishers are coloured red, in accordance with BS EN3, but are also colour coded in accordance with BS7863, which allows for a coloured band to be used to easily identify the extinguisher type. Cream = Foam, Blue = Powder and Black = CO2.

Fire Ratings

The fire ratings achieved by the extinguisher are an indication of how large (or small) a fire can be extinguished with the particular type and size. The higher the number the larger the fire that can be extinguished. However, this needs to be taken into consideration along with two other factors. 1) How large is the fire likely to be before the user decides that he/she can no longer tackle it, and 2) how physically able is the likely user to use the extinguisher effectively, generally the larger the rating the larger the extinguisher.

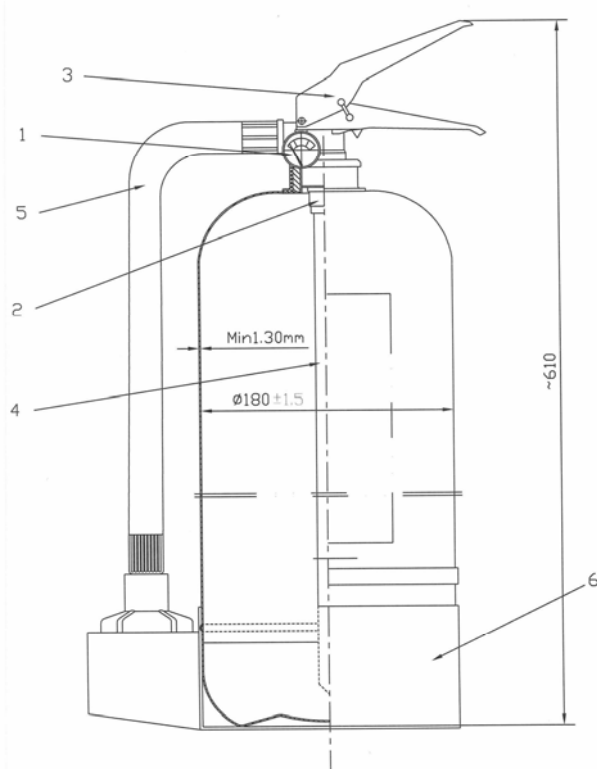

Spare part list

No.	Description	Code
1	Gauge	TTEL64
2	Valve	TTEL27
3	Pin	TTEL66
4	Syphon Tube	TTEL76
5	Discharge Hose	TTEL48
6	Base	TTEL58

No.	Description	Code
	Headcap 'O' Ring	TTEL08
	Discharg 'O' Ring	TTEL09
	Tamper Tag	TTEL07

Maintenance and Guarantee

The extinguisher should be inspected by the user periodically, preferably at least monthly, to ensure that it is in its correct location, has not lost pressure, been used, is in good condition and has not suffered any obvious damage. In addition, the extinguisher should be maintained at least annually, by a competent, preferably BAFE registered technician, in accordance with BS 5306 part 3.

Spare parts and recharge materials must be in accordance with the manufacturers instructions. Failure to comply will invalidate the guarantee.

The extinguisher is guaranteed for a period of 2 years from the date of the supply. The guarantee includes, repair or replacement due to manufacturing defects, unit must be sent back to the factory free of charge, only when written authorisation has been granted.

The guarantee is dependent upon the correct recharge materials and spare parts being used, and the extinguisher must have been regularly maintained by a competent person.