

18321 Carbon Dioxide Wheeled Fire Extinguisher kg 20

EN1866
Certified

Report for conformity according to standard UNI EN 1866-1:2008 nr. 1297-2009



Inflammable liquids,
gasoline, oil etc.

According EN 1866 and with CE-mark

As with portable extinguishers, wheeled units also have to comply with high standards to ensure their extinguishing capability (fire rating), quality and reliability.

We at a.b.s. know how important it is to make the right choice in fire fighting.

Recently, a new European standard for wheeled extinguishers, EN 1866, was introduced.

The a.b.s. wheeled extinguisher range is one of the first in Europe to comply with this standard.

The wheeled units also carry the CE mark so the range can boast three quality guarantees :a.b.s. (ISO 9001), compliance with EN 1866 and the CE mark.

The standard EN1866 defines important minimum levels of pressure retention, corrosion protection, operating temperatures and fire rating.

Technical Characteristics

18321 wheeled extinguishers are designed for professional use under severe circumstances, resulting in a high level of quality and ease of use.

The heart of the wheeled carbon dioxide extinguisher is the 34 CrMo4 steel co2 cylinder with CE approval.

Ease of mobility is achieved as a result of the large wheels with solid rubber tyres and push bar also ensuring good stability during operation.

Trolley

Standard frame is made by steel tube painted with yellow epoxy-polyester paint resistant to the atmospheric aggression and to the UV rays. Optional black or red.

3/4" handwheel valve

The valve is brass (ST-CW617N - EN 12420), and it has exceeded the essential requirements of directive 97/23/EC; it is equipped with a safety device tuned at 235 ±15 bars.

A safety seal on the valve improve the optical check of it from far.

Discharge device

Equipped with a highly flexible 5m hose with an excellent resistance manufactured from selected synthetic materials, complete with an high performance discharge horn with incorporated insulating handle against hand frozen complete with one brass nozzle with side outlet which creates a very efficient snow cloud. An high pressure ball valve is mounted before the horn in order to control the discharge.

Extinguishing agent

Carbon dioxide is a odourless and less colour gas.

It weigh about 1.5 times the air; it does not wet, dirty and it does not damage objects. The CO2 used in the extinguishers is 99% pure and it is moisture-less. CO2 is compressed in liquid phase inside the high pressure cylinder.

In normal conditions 1 Kg of liquid CO2 produces approx. 520 litres of vapour gas.

At 20°C the pressure inside the cylinder is about 55-60 bar.

Filling ratio: 66% = 18 kg suggested for tropical climate conditions if exported in middle east or hot countries. In North Countries the maximum recommended filling ratio is 75% = 20 kg continental standard.



Advantages 18321 wheeled extinguishers

- Very mobile and easy to operate
- Excellent quality, therefore a long operational lifetime
- Good ergonomoy, easy to drive
- Extremely high ratings on B class fire (liquid fuels)
- Can be used at low temperatures (-30°C)
- Easy to service
- First in Europe in accordance with the new EN 1866 standards
- With CE approval

- Test method and result -

The 233B tray has been used and four 21B trays have been installed alongside, as from the following design.

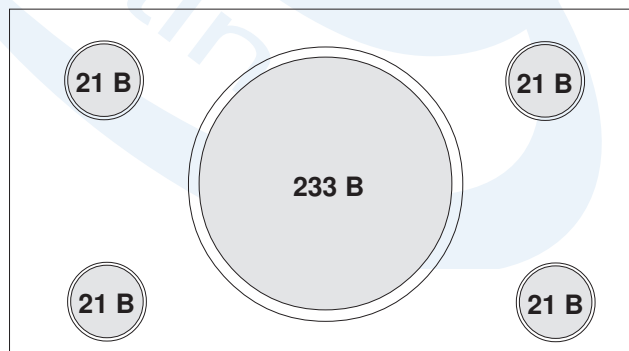

The propellant used has been heptane.

Two fire tests have been performed, with extincion time of respectively 9 and 10 seconds; the test result was positive.

Classification obtained: - **EN 1866 - 233 IV B** - the highest.



Inflammable liquids,
gasoline, oil etc.

Technical specifications

Cylinder "Ø".....	: 203 mm	Extinguishing agent.....	: Carbon Dioxide
Material.....	: Steel 34Cr Mo4	Propellant.....	: Carbon Dioxide
Operating pressure.....	: 60 bar at 20°C	Nominal charge.....	: 20 Kg
Test pressure according 97/23/EC.....	: ≥ 250 bar	Discharge time ~.....	: 32 sec
Burst pressure.....	: > 450 bar	Jet length ~.....	: 4 m
Temperature range.....	: -30°C +60°C		

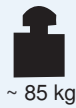
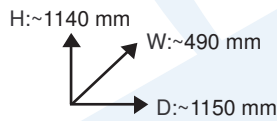

233 B

Spare part list

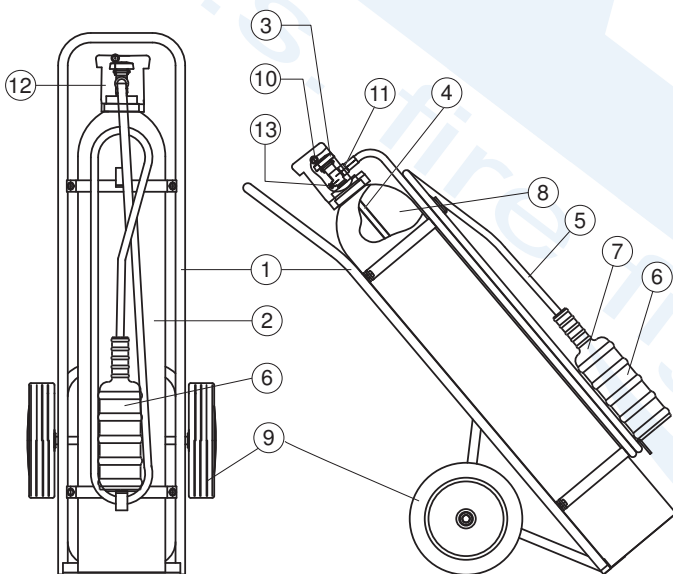

Pos.	Description	Code	Q.ty
1	Frame of the trolley	21013	1
2	Cylinder (27 lt) PED-CE	21330	1
3	3/4" Handwheel valve	21802	1
4	Siphon tube	21704	1
5	Discharge hose	20634	1
6	Discharge apparatus	21029	1
7	Nozzle	20430	1
8	Carbon dioxide	32001	20/18
9	Wheel Ø 300 mm	21931	2
10	Safety seal	28004	1
11	Washer ring fibre 11,6x18,5x2	21036	1
12	Protection cap	21017	1
13	Safety disc	21020	1

The use of non original spare parts may cause malfunctions loss

Maintenance and Guarantee

Maintenance must be made periodically by, trained and certified staff, according to the local regulations of the country where it is located. The extinguisher is guaranteed for 24 months from the date of the supply. The guarantee includes, repairing or replacement for production defects, unit must be sent back to the factory free of charge, only when authorized written agreement with our sales office has been reached. The guarantee expires in case of tampering and bad maintenance made by not-authorized staff. It must be recharged only by staff authorized and certified by a.b.s. S.r.l., use only genuine original spare parts.