

18260_1 Foam Wheeled Fire Extinguisher It 50 Stainless steel

CO2 cartridge, 4" large headcap, welded frame.

EN1866
certified



Organic solid materials,
wood rubber, textiles etc.



Inflammable liquids,
gasoline, oil etc.

According EN 1866 and with CE-mark

As with portable extinguishers, wheeled units also have to comply with high standards to ensure their extinguishing capability (fire rating), quality and reliability.

We at a.b.s. know how important it is to make the right choice in fire fighting.

Recently, a new European standard for wheeled extinguishers, EN 1866, was introduced.

The a.b.s. wheeled extinguisher range is one of the first in Europe to comply with this standard.

The wheeled units also carry the CE mark so the range can boast three quality guarantees :a.b.s. (ISO 9001), compliance with EN 1866 and the CE mark.

The standard EN1866 defines important minimum levels of pressure retention, corrosion protection, operating temperatures and fire rating.

Technical Characteristics

18260_1 wheeled extinguishers are designed for professional use under severe circumstances, resulting in a high level of quality and ease of use.

The heart of the wheeled foam extinguisher is the stainless steel foam tank with CE approval.

Ease of mobility is achieved as a result of the large wheels with solid rubber tyres and push bar also ensuring good stability during operation.

Headcap 4" BSP

The headcap is made of brass and equipped with a spring loaded safety valve to prevent an unsafe situation, as a result of overfilling or during accidental unscrewing from the cylinder neck gear.

Discharge device

Equipped with a highly flexible 5m hose made in EPDM rubber with an excellent resistance manufactured from selected synthetic materials complete with a pistol.

The specially designed ergonomic patented foam nozzle ensures a steady flow of foam with a very low drop in pressure.

Propellant bottle

The carbon dioxide bottle, chromemolybdenum carbon steel, is made according to directive EN 1964-1 ECC.

Before painting it is cleaned by sand blasting thus ensuring a raw surface for a perfect and strong grasp of the epoxy polyester powder coating.

This red RAL 3000 u.v. repellent is resistant to scratches and knocks as well to corrosive weather conditions. It is delivered complete with a brass handwheel valve and safety valve.

Extinguishing agent

Sealfire® Super concentrate is the most powerful product registered by a.b.s. s.r.l. formulated for fire extinguisher. It is an additive AFFF based, specially formulated for best sealing effects.



Advantages 18260_1 wheeled extinguishers

- Very mobile and easy to operate
- Excellent quality, therefore a long operational lifetime
- Good ergonomics, easy to drive
- Extremely high ratings on A, B fires (solid combustibles, liquid fuels)
- Can be used at low temperatures (+0°C) On request -30°C or -20°C.
- Easy to service
- First in Europe in accordance with the new EN 1866 standards
- With CE approval
- Other Foam types available.

- Test method and result -

The 233B tray has been used and four 21B trays have been installed alongside, as from the following design.

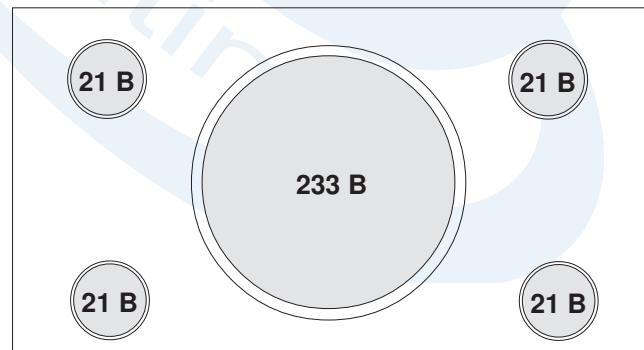

The propellant used has been heptane.

Two fire tests have been performed, with extinction time of respectively 9 and 10 seconds; the test result was positive.

Classification obtained: - **EN 1866 - 233 IV B** - the highest.

18260 is available with nitrogen cylinder, 2" headcap, hose 10 mt length.



Organic solid materials,
wood rubber, textiles etc.



Flammable liquids,
gasoline, oil etc.

Technical specifications

Cylinder "Ø".....: **315 +0 -15 mm**
 Material.....: **AISI 304**
 Operating pressure.....: **14 bar a 20°C**
 Test pressure according 97/23/EC.....: **30 bar**
 Burst pressure.....: **>55 bar**
 Temperature range.....: **+0°C +60°C**

Extinguishing agent A.F.F.....: **2% Sealfire®**
 Propellant cylinder.....: **CO₂ 3lt (1.3kg CO₂)**
 Nominal charge.....: **50 lt**
 Discharge time ~.....: **46 sec**
 Jet length ~.....: **8 m**
Available antifreeze -20°C or -30°C

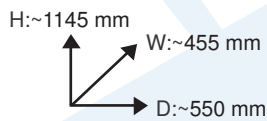

Spare part list

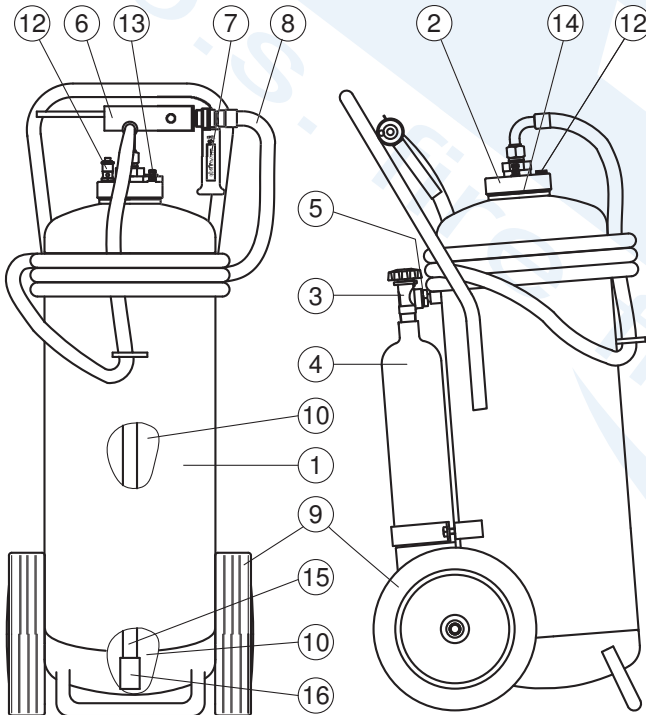

Pos.	Description	Code	Q.ty
1	Cylinder (lt 64) PED-CE Stainless Steel	27828	1
2	Cap G.4"	21144	1
3	Handwheel valve	20831	1
4	3 lt CO ₂ Cylinder PED-CE	20302	1
5	Adaptor for CO ₂ cylinder	20007	1
6	Foam nozzle light alloy	21006	1
7	Trigger valve brass 3/4"	66030	1
8	Discharge hose L 5 mt	20656	1
	On request Discharge hose L 10 mt	20656_1	
9	Ø 300 mm wheels rubber and plastic	21931	2
10	Sealfire	21093	1,5 lt
11	Gasket for discharge hose	21021	1
12	Safety valve 1/4" (22 bar)	28024	1
13	Check valve	21010	1
14	Pressure gauge Ø 23	20516	1
15	Siphon tube	21706	1
16	3/4 Filter + coupling	83011 + 20024	1

The use of non original spare parts may cause malfunctions loss

Maintenance and Guarantee

Maintenance must be made periodically by, trained and certified staff, according to the local regulations of the country where it is located. The extinguisher is guaranteed for 24 months from the date of the supply. The guarantee includes, repairing or replacement for production defects, unit must be sent back to the factory free of charge, only when authorized written agreement with our sales office has been reached. The guarantee expires in case of tampering and bad maintenance made by not-authorized staff. It must be recharged only by staff authorized and certified by **a.b.s. S.r.l.**, use only genuine original spare parts.