

18131 Powder Wheeled Fire Extinguisher kg 25

CO2 cartridge, headcap 2", welded frame.

Report for conformity according to standard UNI EN 1866-1:2008 nr. 1426-2009

EN1866
 Certified



Organic solid materials,
 wood rubber, textiles etc.



Inflammable liquids,
 gasoline, oil etc.



Inflammable gases,
 methane, propane.

According EN 1866 and with CE-mark

As with portable extinguishers, wheeled units also have to comply with high standards to ensure their extinguishing capability (fire rating), quality and reliability.

We at a.b.s. know how important it is to make the right choice in fire fighting.

Recently, a new European standard for wheeled extinguishers, EN 1866, was introduced.

The a.b.s. wheeled extinguisher range is one of the first in Europe to comply with this standard.

The wheeled units also carry the CE mark so the range can boast three quality guarantees :a.b.s. (ISO 9001), compliance with EN 1866 and the CE mark.

The standard EN1866 defines important minimum levels of pressure retention, corrosion protection, operating temperatures and fire rating.

Technical Characteristics

18131 wheeled extinguisher is designed for professional use under severe circumstances, resulting in a high level of quality and ease of use.

The heart of the wheeled powder extinguisher is the steel powder tank with CE approval.

Ease of mobility is achieved as a result of the large wheels with solid rubber tyres and push bar also ensuring good stability during operation.

Headcap 2" BSP

The headcap is made of brass and equipped with a spring loaded safety valve to prevent an unsafe situation, as a result of overfilling or during accidental unscrewing from the cylinder neck gear.

Discharge device

Equipped with a highly flexible 5m hose made in EPDM rubber with an excellent resistance manufactured from selected synthetic materials complete with a pistol.

The specially designed ergonomic patented pistol ensures a steady flow of powder with a very low drop in pressure.

Propellant bottle

The carbon dioxide bottle, chromemolybdenum carbon steel, is made according to directive EN 1964-1 ECC.

Before painting it is cleaned by sand blasting thus ensuring a raw surface for a perfect and strong grasp of the epoxy polyester powder coating.

This red RAL 3000 u.v. repellent is resistant to scratches and knocks as well to corrosive weather conditions. It is delivered complete with a brass handwheel valve and safety valve.

Extinguishing agent

Dry chemical powder German is produced according to EN 615 and ISO 9000 quality control.

The basic components of dry powder are ammonium phosphate and ammonium sulphate with special silicone additives enabling easy discharge and avoiding any caking process.

Dry powder is non-corrosive, non-abrasive, and is non toxic for humans and animals.

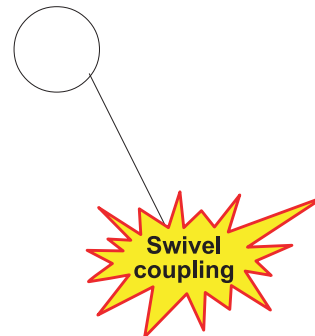

Advantages 18131 wheeled extinguishers

- Very mobile and easy to operate
- Excellent quality, therefore a long operational lifetime
- Good ergonomoy, easy to drive
- Extremely high ratings on A, B and C class fires (solid combustibles, liquid fuels and gases)
- Can be used at low temperatures (-30 °C)
- Easy to service
- First in Europe in accordance with the new EN 1866 standards
- With CE approval
- Other dry powder types available (BC, Monnex)

- Test method and result -

The 233B tray has been used and four 21B trays have been installed alongside, as from the following design.

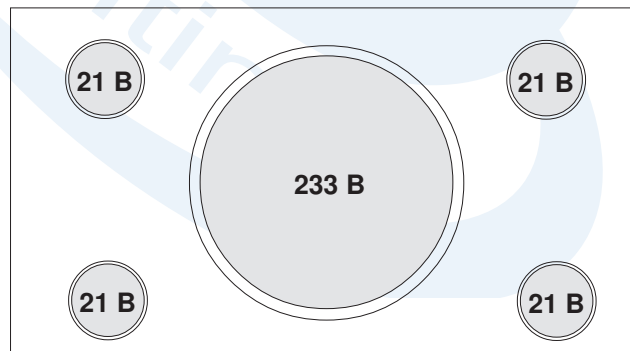

The propellant used has been heptane.

Two fire tests have been performed, with extincion time of respectively 9 and 10 seconds; the test result was positive.

Classification obtained: - **EN 1866 - 233 IV B** - the highest.

18131 is also available with nitrogen cylinder, and large headcap 4".



Organic solid materials,
wood rubber, textiles etc.



Flammable liquids,
gasoline, oil etc.



Flammable gases,
methane, propane.

Technical specifications

Cylinder "Ø".....	: 245 mm +0 -15 mm	Extinguishing agent.....	: Powder MAP ABC 30
Material.....	: DD12 UNI EN 10111	Propellant.....	: (2 kg CO2)
Operating pressure.....	: 14 bar at 20°C	Nominal charge.....	: 25 Kg
Test pressure according 97/23/EC.....	: 30 bar	Discharge time ~.....	: 25 sec
Burst pressure.....	: >55 bar	Jet length ~	: 11 m
Temperature range.....	: -30°C +60°C		

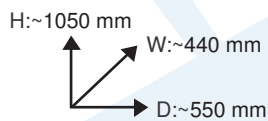

Spare part list

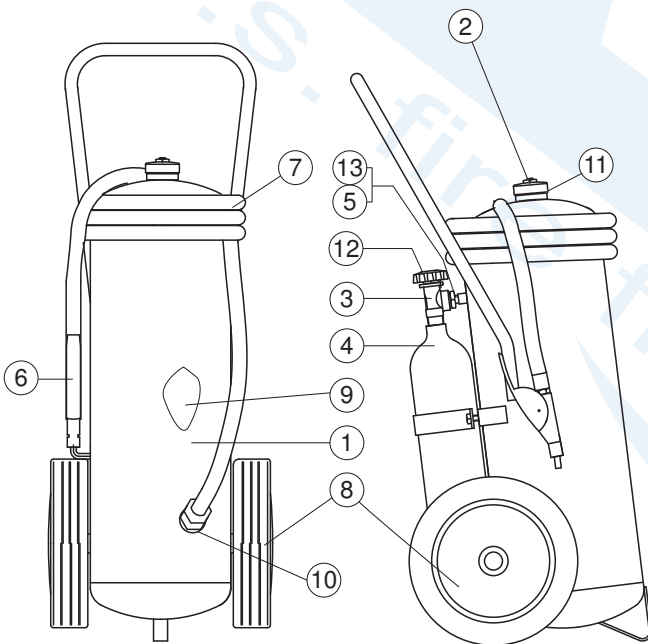

Pos.	Description	Code	Q.ty
1	Cylinder (~ lt 33) PED-CE	27704	1
2	Cap G. 2" with safety valve	21034	1
3	Handwheel valve	20831	1
4	3 lt CO ₂ cylinder PED-CE	20302	1
5	Adaptor for CO2 cylinder	20007	1
6	Discharge pistol	21035	1
7	Discharge hose L 5 mt	20649	1
8	Ø 300 mm wheels rubber and plastic	21931	2
9	Powder ABC MAP 30%	31230	25
10	Washer ring fibre 3/4" - 15,2x24x2	20021	1
11	Washer black rubber 2" - 56x41x3	20022	1
12	Plastic seal	28004	1
13	Washer ring fibre 11,6x18,5x2 M	21036	1

The use of non original spare parts may cause malfunctions loss

Maintenance and Guarantee

Maintenance must be made periodically by, trained and certified staff, according to the local regulations of the country where it is located. The extinguisher is guaranteed for 24 months from the date of the supply. The guarantee includes, repairing or replacement for production defects, unit must be sent back to the factory free of charge, only when authorized written agreement with our sales office has been reached. The guarantee expires in case of tampering and bad maintenance made by not-authorized staff. It must be recharged only by staff authorized and certified by **a.b.s. S.r.l.**, use only genuine original spare parts.